

**LUGOIOPS MAYA, A NEW GENUS AND SPECIES OF EPHEMEROPTERA  
(BAETIDAE) FROM CENTRAL AMERICA**

W. P. McCAFFERTY AND D. E. BAUMGARDNER

(WPM) Department of Entomology, Purdue University, West Lafayette, IN 47907, U.S.A. (e-mail: pat\_mccafferty@entm.purdue.edu); (DEB) Department of Entomology, Texas A & M University, College Station, TX 77843, U.S.A. (e-mail: dbaumgardner@tamu.edu)

---

*Abstract.*—Small minnow mayfly (Ephemeroptera: Baetidae) larvae taken from a mountain rivulet in Baja Verapaz, Guatemala are described as *Lugoiops maya*, **new genus and new species**. The new genus is a member of the *Baetodes* complex of genera, being more advanced than *Moribaetis* or *Mayobaetis*, and sharing numerous synapomorphies with both *Prebaetodes* and *Baetodes*, and additional synapomorphies with *Baetodes*. The precise cladistic relationships deduced for the new genus are discussed and a new key to genera of the *Baetodes* complex is provided. Larvae of *L. maya* are striking because of their relatively large size, unique structural characteristics, such as absence of gills 1, and their torrential habitat.

*Key Words:* *Lugoiops*, new genus, new species, Baetidae, Guatemala

---

With the recent discovery of the genus *Prebaetodes* Lugo-Ortiz and McCafferty in Colombia and Ecuador (Lugo-Ortiz and McCafferty 1996), an essential phylogenetic link was found that demonstrated the relationship of the highly apotypic Western Hemisphere genus *Baetodes* Needham and Murphy with more typical baetines, vis-à-vis the Western Hemisphere genera *Moribaetis* Waltz and McCafferty and *Mayobaetis* Waltz and McCafferty. As a result, the phylogenetic origin of what had been an anomalous genus was hypothesized for the first time, and a distinctive monophyletic group of genera, the *Baetodes* complex, was delineated in the Western Hemisphere. McCafferty (1998) applied the cladistic relationships within the *Baetodes* complex to biogeographic analysis to show that the origin of the Pan-American genus *Baetodes* was clearly Neotropical, as was that of other members of the complex. The biogeog-

raphy of this complex was further elucidated by McCafferty (1999).

Recently, larvae of relatively large and unusual small minnow mayflies collected from a mountain rivulet in Guatemala in July of 2001 were sent to WPM independently by W. D. Shepard (Sacramento, California) and DEB for examination. These larvae proved to be an unknown member of the *Baetodes* complex of Baetidae, sharing for example, the apicolateral setal row found on the denticulate claws throughout the complex, a thickened labrum also common throughout much of the complex, and absence of the villopore and other characteristics associated with other complexes of Baetidae. Study of the character state distribution and cladistic relationships within the *Baetodes* complex revealed that the species should not be subsumed by any other genus in the complex and that a new genus was justified within the context of a strictly

phylogenetic classification (see below). At the same time, the newly discovered lineage provided additional cladistic characterization that further demonstrated the morphological transition from the more stereotypic minnowlike baetid larval form to the highly apotypic and unusual *Baetodes* form. Moreover, its phenetic distinctiveness makes recognition at the generic level practical. Below, we describe the new genus and species, and provide associated cladistic, diagnostic, and habitat data.

We are honored to name the genus after Carlos Lugo-Ortiz (Cidra, Puerto Rico), who in recent years has contributed the primary thrust in the discovery and elaboration of the biodiversity of the family Baetidae in the Neotropics as well as the Southern Hemisphere in general, but especially Africa and Madagascar. The work of Dr. Lugo-Ortiz has provided the basis for further research on the Baetidae by establishing standards of description and analysis, diligently seeking to bring the taxonomy of Baetidae in line with modern systematics that recognizes taxa as discreet inter-related phylogenetic lineages. The gender of the genus is masculine.

***Lugoiops* McCafferty and  
Baumgardner,  
new genus  
(Figs. 1–11)**

Larva.—*Head*: Orientation (Figs. 1–2) extremely hypognathous. Antenna (Figs. 1–2) approximately one and one-half times length of head capsule length; scape and pedicel subcylindrical in cross-section, with tufted row of fine, simple setae dorsolaterally. Lateral margins of frons broadly connecting to clypeus (Fig. 2). Labrum (Figs. 2–3) basally somewhat constricted, with lateral margins rounded, relatively short, not expanded to nearly round overall shape; dorsal surface with slightly bulbous prominence basomedially and two such laterally. Mandible (Figs. 4–5) not continuously convex laterally; denticles not fan shaped. Labial palp (Fig. 8) three-segmented, with

segment 1 and 2 subequal in length and with short, somewhat dome-shaped segment 3. *Thorax*: Legs (Figs. 1, 9) elongate, outspread from body; tibiae slightly twisted. Hindwingpad very small. *Abdomen*: terga lacking tubercles or patches of setae. Gills present on segments 2–7 (Fig. 1), dorsolaterally oriented but overlapping abdominal pleura. Paraprocts (Fig. 11) without marginal denticulation. Median caudal filament reduced to unsegmented conical vestige (Fig. 1). Cercus (Fig. 1) bare, lacking medial setae and lateral spination.

Type species.—*Lugoiops maya*, n. sp.

Discussion.—*Lugoiops* larvae are distinctive in many ways, but especially because of their large size along with their elongate, outspread legs, the vestigial median caudal filament, and the absence of gills 1. Edmunds et al. (1976) gave the body length dimensions of *Baetodes* larvae as 3.0 to 8.0 mm. This size range is also applicable to known *Prebaetodes* (Lugo-Ortiz and McCafferty 1996). *Moribaetis* and *Mayobaetis* larvae, which have generally been considered to be rather large baetids have lengths of up to about 10.0 mm. Known *Lugoiops* larvae by these standards, however, are even larger, being around 12.0–13.0 mm when mature. A modified key to the larval stage of genera of the *Baetodes* complex that includes *Lugoiops* and additional comparative characterization within the complex is included below.

With application of the cladistic analysis of Lugo-Ortiz and McCafferty (1996) and character state polarity and distribution presented by them, along with new character assessment and re-analysis herein, we have been able to place *Lugoiops* within the hypothesized cladogram. Demonstrative of its placement in the *Baetodes* complex, *Lugoiops* shares a primary synapomorphy defining that complex, i.e., the possession of apicolateral setation on the denticulate claws. *Lugoiops* also possesses a basomedial prominence dorsally on the labrum, which Lugo-Ortiz and McCafferty (1996) had originally indicated was an apomorphy

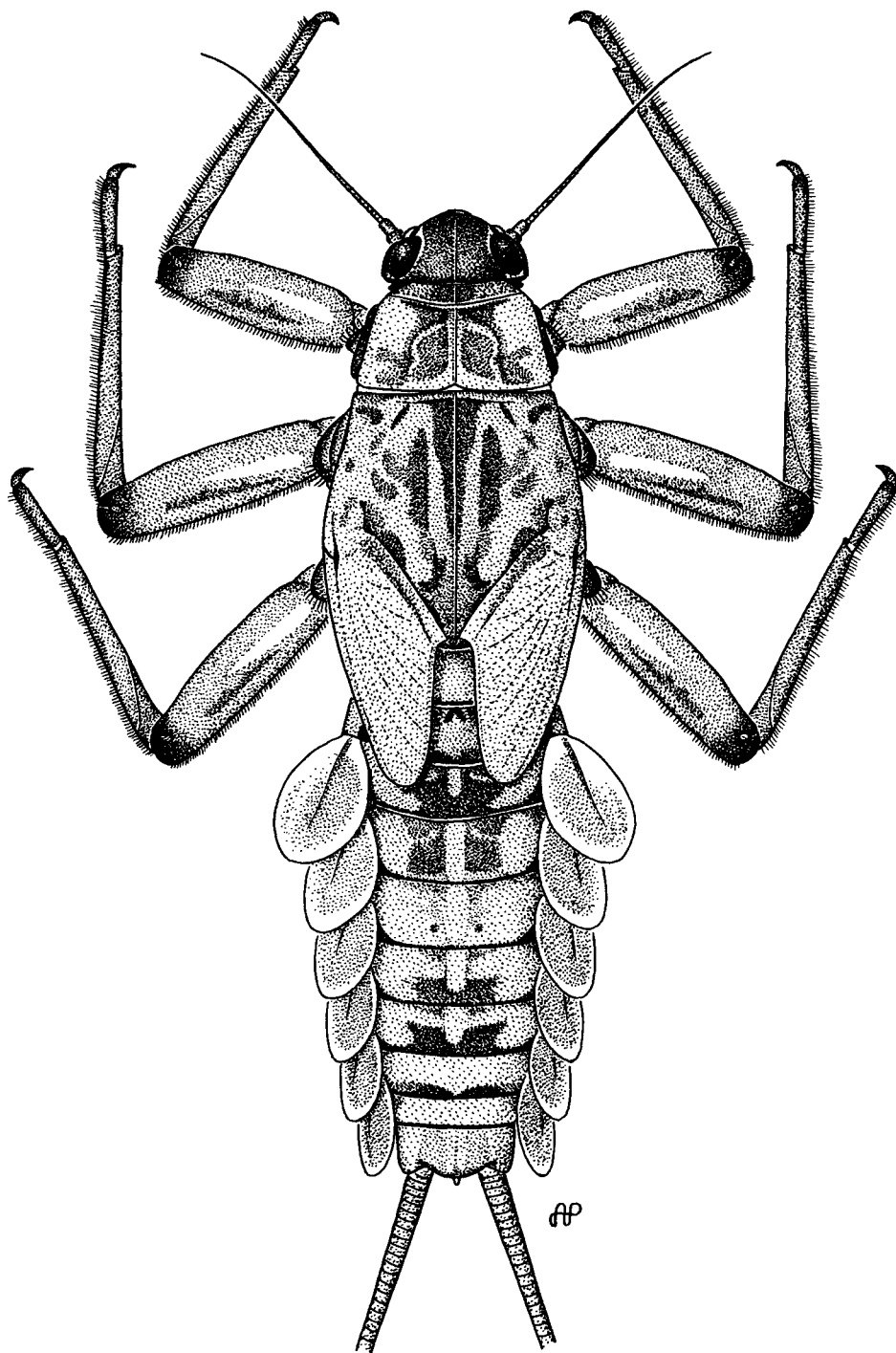

Fig. 1. Larval habitus of *Lugoziops maya*.

found only in *Moribaetis*. However, we have found such a labrum not only in *Lugoiops*, but also to a lesser extent in *Mayobaetis* and also in *Baetodes*, where it can be highly developed in some species, e.g., *B. inermis* Cohen and Allen. Therefore, that characteristic should no longer be considered a restricted autapomorphy within the *Baetodes* complex, but likely may very well have been present ancestrally in the complex and as such an apomorphy that further helps define this monophyletic grouping of genera.

Within the *Baetodes* complex, *Lugoiops* shares all of the synapomorphies defining the clade made up of *Mayobaetis*, *Prebaetodes*, and *Baetodes*, i.e., the lack of marginal denticulation on the paraprocts, the dorsolateral setation at the base of the antennae, and reduced median caudal filament. *Lugoiops* does not share the single apomorphy, involving the unique attenuated frons, that is associated with the relatively plesiotypic genus *Moribaetis* within the complex.

*Lugoiops* does not possess any of the autapomorphies that are identified with the individual *Mayobaetis* lineage, i.e., lateral spination on the cerci and dorsoventrally flattened antennal scapes and pedicels. On the other hand, it does share synapomorphies previously shown to be common to *Prebaetodes* and *Baetodes*, including an even shorter median caudal filament, elongate legs, and the slightly twisted tibiae.

*Lugoiops* does not share any of the apomorphies that Lugo-Ortiz and McCafferty (1996) used to distinguish the individual *Prebaetodes* lineage, having neither the laterally convex mandibles nor expanded and nearly round labrum that are autapomorphic in *Prebaetodes*. Also, based on the cladistic analysis of Lugo-Ortiz and McCafferty (1996), except for an even shorter median caudal filament, *Lugoiops* does not share apomorphies that distinguish the individual *Baetodes* lineage, i.e., the apomorphic abdominal gill arrangement (1–5) or the dorsal abdominal armature.

A strong indication of the sister relationship of *Lugoiops* within this apotypic *Lugoiops-Prebaetodes-Baetodes* clade, however, is demonstrated by at least one compelling character state that we are able to add to the analysis, that is the complete loss of medial setae (swimming hairs) on the cerci of both *Lugoiops* and *Baetodes*.

The loss of gills 1 in *Lugoiops* is an autapomorphy within the complex. Another characteristic possibly unique to the *Lugoiops* lineage includes the reduction of the median caudal filament to a minute, unsegmented, conical vestige. However, we cannot be absolutely sure such a middle tail vestige is unique to *Lugoiops*, because although considerable material of *Baetodes* that we have studied consistently have quite short (always less than one-fifth the cercus length) but segmented middle tails, Edmunds et al. (1976) stated that the middle tails of *Baetodes* were reduced to stubs, and thus that might indicate that they had seen specimens with unsegmented vestiges as we have observed in *Lugoiops*.

Regardless of the fine degree of reduction of the median caudal filament, *Prebaetodes* and *Baetodes* could also be considered two-tailed in the vernacular along with *Lugoiops*. Certain two-tailed, rheophilic baetid larvae throughout the world also have developed tergal tubercles or setal patches (e.g., Lugo-Ortiz and McCafferty 1999, Lugo-Ortiz et al. 2001, Jacobus and McCafferty 2001). Although this is also the case in *Baetodes*, there is no indication of such development in *Prebaetodes* or *Lugoiops*.

In *Moribaetis*, *Mayobaetis*, and *Prebaetodes*, the gills are held outspread from the abdomen, or if appressed are oriented dorsal of the abdominal pleura. In *Lugoiops* and many *Baetodes* (e.g., see abdominal illustrations in Cohen and Allen [1978]), the gills are held appressed to the abdomen more or less over the pleura. Also in *Baetodes*, the gills are often held out from the abdomen ventral of the abdominal pleura, thus leading to the standard descriptor of

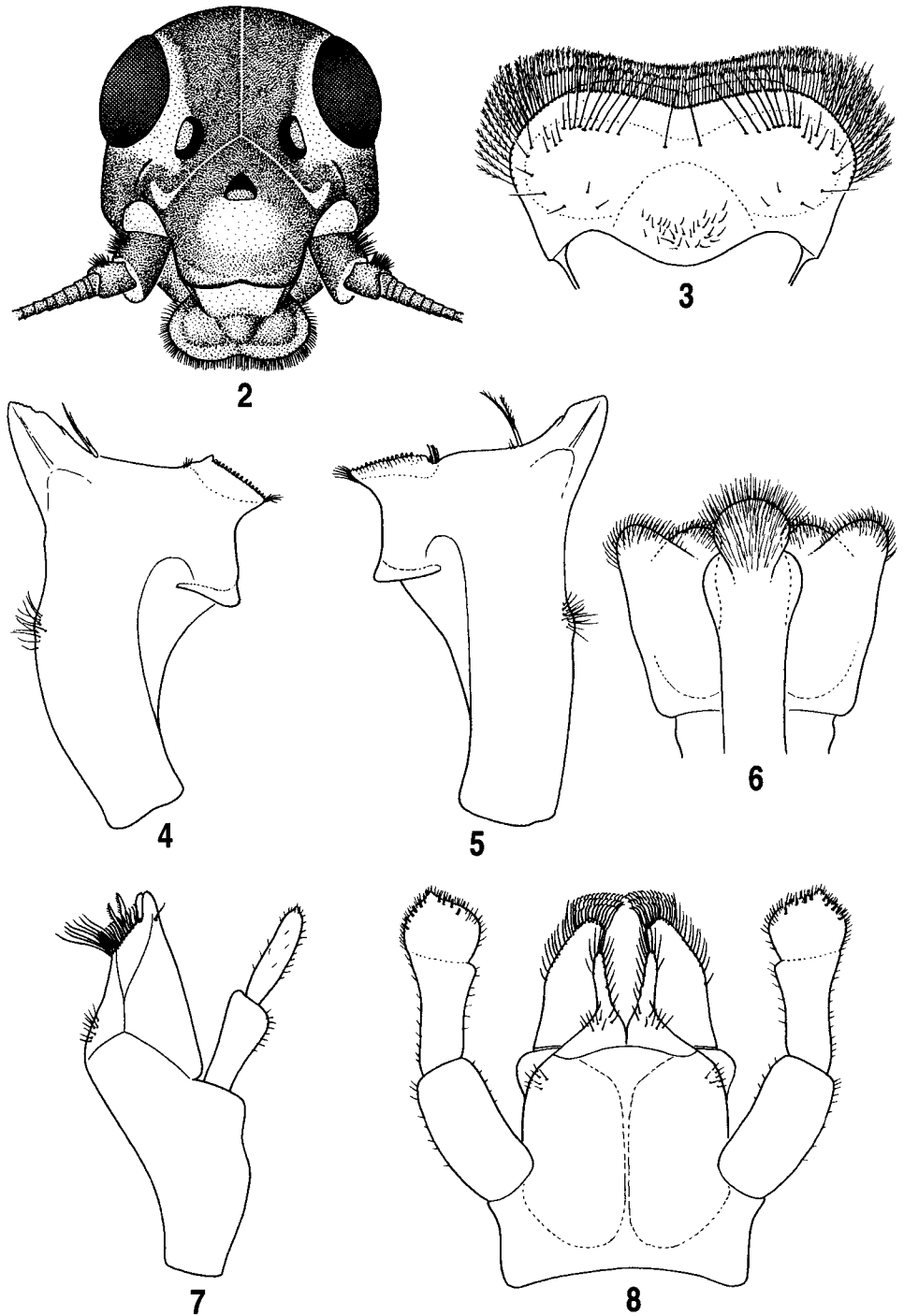

Figs. 2-8. *Lugoioops maya*, larva. 2, Head (frontal). 3, Labrum (dorsal). 4, Angulate mandible. 5, Planate mandible. 6, Hypopharynx. 7, Maxilla. 8, Labium.

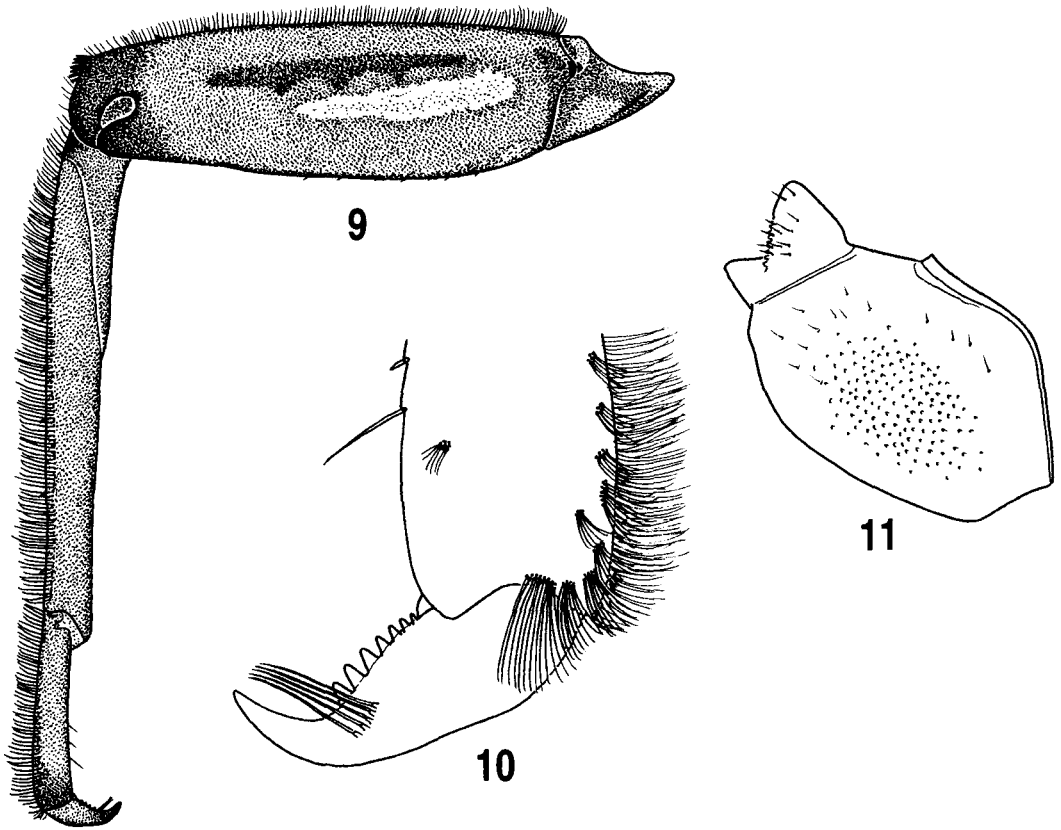

Figs. 9–11. *Lugoioops maya*, larva. 9, Foreleg (anterior face). 10, Claw. 11, Paraproct.

*Baetodes* larvae as having ventral gills. From these observations, it appears that laterally appressed gills, especially as seen in the more posterior gills of *Lugoioops*, may have been the condition in the most immediate common ancestor to the *Lugoioops*-*Baetodes* clade. This orientation developed into an extreme ventral orientation within *Baetodes*.

Hindwings are not present in *Baetodes* alates; however, hindwingpads can be either vestigial or entirely lacking in the larvae of *Baetodes*, which indeed are also intergenerically variable with respect to the degree of labral thickening and degree of ventral orientation of the gills, as mentioned above. The hindwingpad variable conditions are not without precedence among other baetids, even within the same species, as is illustrated by the North American *Acentrella*

*turbida* (McDunnough), where in some larvae there are vestigial hindwingpads and in others there are none (see McCafferty et al. 1994). It is not all together clear from the very small size of the hindwingpads whether the alates of *Lugoioops* will lack hindwings or have only minute hindwings. In either case, this is an unusual instance among Ephemeroptera, where a large mayfly would have this amount of reduction in hindwings, because such reduction has usually been regarded to be associated with body size reductionism in general (McCafferty and Waltz 1990). Another atypical example of such hindwing reduction in a large alate mayfly is represented by the very small hindwings found in the large *Dipteromimus* McLachlan mayflies (Pisiforma: Dipteromimidae) in Japan. If the hindwings are indeed present in the alates

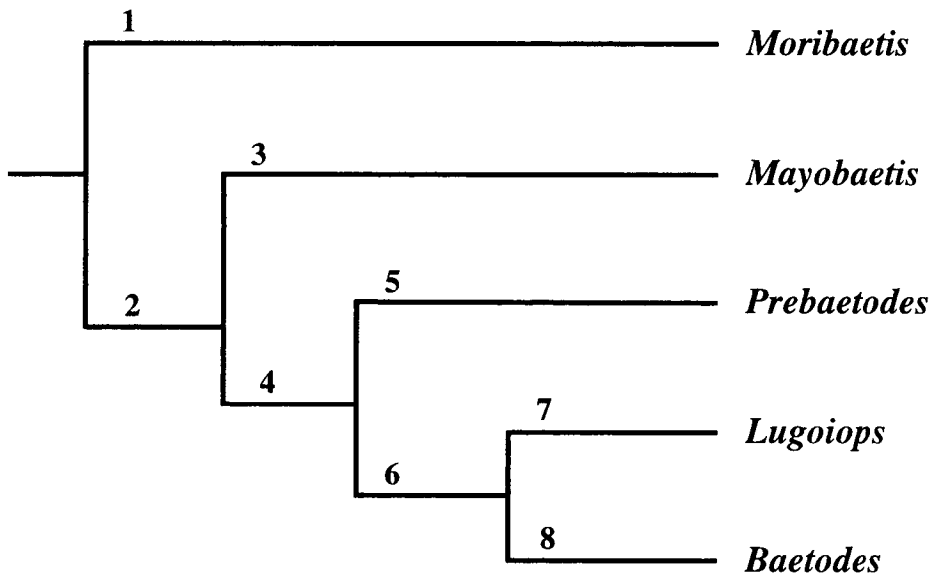

Fig. 12. Derived cladogram of the *Baetodes* complex. Evidential apomorphies (see text also): 1—frons attenuate; 2—loss of paraproct marginal denticulation, basal antennal setation developed, some shortening of middle tail; 3—lateral cerci spines present, scape and pedicel depressed; 4—additional shortening of middle tail, reduction of middle tail setation, elongation of legs, slight twist of tibiae; 5—laterally convex mandibles, expanded labrum; 6—cerci bare, middle tail more shortened, gill not outspread or held dorsal to abdominal pleura; 7—gills 1 lost, middle tail unsegmented; 8—gills 6 and 7 lost, gills can be held ventral of abdominal pleura, armature present on middle abdominal terga.

of *Lugoioops*, then the complete loss of the alate hindwings in *Prebaetodes* and *Baetodes*, could be seen as a convergence related to size reduction in those two lineages, because other members of the complex are all relatively good sized baetids. Such hindwing loss is subject to homoplasy throughout many baetid clades.

Lugo-Ortiz and McCafferty (1996) noted only antennal pedicel setation in the cladistic character state distributions among the *Baetodes* complex, and, as indicated above, its commonality in *Mayobaetis*, *Prebaetodes*, and *Baetodes* (to which can now be added *Lugoioops*). In actuality, *Prebaetodes* and *Baetodes* have antennal base setation essentially confined to the pedicel, whereas *Mayobaetis* and *Lugoioops* have such setation also well developed on the scape. Possible explanations of this, given the preponderance of cladistic evidence stated here, is that the common ancestor of the *Mayobaetis-Prebaetodes-Lugoioops-*

*Baetodes* clade possessed setation on both the pedicel and scape and it became independently reduced on the scapes of *Prebaetodes* and *Baetodes*, or alternatively, that it developed independently on the scapes of *Mayobaetis* and *Lugoioops*. Because there is no knowledge of any function related to the various arrangements, we are left with no clue as to which alternative may be more probable. It is certainly possible that further review of the speciose genus *Baetodes* may reveal some variation of these two arrangements within that genus also.

From the above review and analysis of cladistics, *Lugoioops* falls as a sister genus of *Baetodes*, which together are opposite *Prebaetodes* within this advanced clade of the *Baetodes* complex. Our entire hypothesized cladogram can be seen in Fig. 12. Sequencing conventions allow each of the sequenced lineages as described above to be recognized at the same taxonomic level—in this case the genus level.

KEY TO THE LARVAE OF GENERA OF THE  
WESTERN HEMISPHERE *BAETODES* COMPLEX

1. Tarsal claws with 1–5 or more setae on apicolateral aspect of denticulate claws (Fig. 10; figs. 9, 15, 32, 39 [Lugo-Ortiz and McCafferty 1996]); villopore absent; labrum often raised over dorsal surface into three broad mounds or at least thickened basomedially (Fig. 2; figs. 2, 5 [Lugo-Ortiz and McCafferty 1996]) . . . . . *Baetodes* complex, 2
  - Tarsal claws without setae as above; villopore present or absent; labrum not thickened as above . . . . . other Western Hemisphere Baetidae
2. Median caudal filament over one-half length of cerci (fig. 10 [Lugo-Ortiz and McCafferty 1996]); antennal pedicels lacking rows of tufts of setae in dorsal or lateral aspect (fig. 7 [Lugo-Ortiz and McCafferty 1996]; figs. 2–5 [Waltz and McCafferty 1985]); hindwingpads relatively well developed . . . . . *Moribaetis*
  - Median caudal filament less than one-half length of cerci (Fig. 1; figs. 16, 37, 41 [Lugo-Ortiz and McCafferty 1996]); antennal pedicels with row or tuft of setae dorsolaterally (Fig. 2; figs. 12, 25, 38 [Lugo-Ortiz and McCafferty 1996]); hindwingpads variable or absent. . . . . 3
3. Gills present on abdominal segments 1–5 (figs. 9–24 [Cohen and Allen 1978]; fig. 40 [Lugo-Ortiz and McCafferty 1996]), ventral or appressed laterally; middle abdominal terga with tubercles or setal patches . . . . . *Baetodes*
  - Gills present on abdominal segments 1–7 or 2–7 (Fig. 1; fig. 12 [Waltz and McCafferty 1985]; fig. 33 [Lugo-Ortiz and McCafferty 1996]), outspread, dorsal, dorsolaterally or laterally appressed; abdominal terga without tubercles or setal patches . . . . . 4
4. Cerci without medial setae (Fig. 1); gills present on abdominal segments 2–7 (Fig. 1); median caudal filament reduced to unsegmented vestige (Fig. 1) . . . . . *Lugoiops*
  - Cerci with medial setae (figs. 16, 37 [Lugo-Ortiz and McCafferty 1996]); gills present on abdominal segments 1–7 (gills 1 may be very small) (fig. 12 [Waltz and McCafferty 1985]; fig. 33 [Lugo-Ortiz and McCafferty 1996]); median caudal filament multisegmented short tail (figs. 16, 37 [Lugo-Ortiz and McCafferty 1996]) . . . . . 5
5. Legs slender-elongate (fig. 31 [Lugo-Ortiz and McCafferty 1996]); hindwingpads vestigial; labrum large and near round (fig. 25 [Lugo-Ortiz and McCafferty 1996]); median caudal filament with lateral setae reduced (fig. 37 [Lugo-Ortiz and McCafferty 1996]) . . . . . *Prebaetodes*
  - Legs robust (fig. 14 [Lugo-Ortiz and McCafferty 1996]); hindwingpads relatively well developed; labrum shorter, somewhat quadrate

(fig. 12 [Lugo-Ortiz and McCafferty 1996]); median caudal filament with lateral setae developed (fig. 16 [Lugo-Ortiz and McCafferty 1996]) . . . . . *Mayobaetis*

*Lugoiops maya* McCafferty and  
Baumgardner, new species  
(Figs. 1–11)

Larva.—Mature body (Fig. 1) length 12.0 mm; cercus length 14.5 mm; antenna length 3.0 mm. *Head*: Color brown; frons (Fig. 2) with somewhat diffuse white spot centrally; white areas also between each compound eye and lateral ocellus; lateral branches of frontal suture below but not contacting lateral ocelli. Antennal scape and pedicel (Fig. 2) brown, with white membranous sub-base exposed. Short labrum (Figs. 2–3) slightly emarginate, with thick brush of short marginal setae extending more sparsely along rounded lateral margins. Mandibles shaped as in Figs. 4 and 5, with denticles extremely fused; angulate mandible (Fig. 4) with mola nearly perpendicular to long axis of body of mandible, and with prostheca with only slight branching; prostheca of planate mandible (Fig. 5) long, double and with branching setules in distal two-thirds. Hypopharynx (Fig. 6) setate distally, with lingua narrowly rounded distally, and with superlinguae overlapping bilobular distally. Maxillary palp (Fig. 7) two-segmented, short, extending about as far as nearly conical galealacinae. Labium (Fig. 8) with glossa reduced; paraglossa well developed, with strong apical tuft of brushing setae; labial palp with segment 2 with minute medioapical thumb, and segment 3 with short marginal setae and sparse, small submarginal spines. *Thorax*: Nota (Fig. 1) brown with lighter brown striations and patches; pleura brown with extensive white inter-sclerite areas; sterna white. Legs (Figs. 1, 9) light brown with some markings anteriorly and cream colorous posteriorly; anterior face of femora (Fig. 9) with whitish swordlike mark extending medially from base to somewhat over one-half length of femora, and with



darker diffuse elongate marking (near dorsal edge and dorsad of swordlike mark) extending in middle two-thirds of length of femora; ventral tip of femora overlapping strongly recurved dorsal tip (Fig. 9); thick row of medium sized setae extending along dorsal edge of femora and extending along edge of tibiae and tarsi (Fig. 9); tarsi also with scattered short, stout setae and longer subapical bristle on surface opposite inward bend of tarsal claws, and with tufts of fine, hairlike setae apically and along on outer face (Fig. 10). Tarsal claws (Fig. 10) with five to eight denticles, most developed apically, and with five lateroapical, blond setae at base of curved claw tip. *Abdomen*: Abdominal terga light brown with dark brown markings as in Fig. 1, only terga 9 and 10 concolorous medium brown (lighter in younger larvae); terga 3 most darkly marked and tergum 5 least darkly marked. Sterna cream to yellow-brown, without distinctive markings. Paraproct (Fig. 11) with irregular submarginal denticulation.

*Material examined*.—Holotype: Mature larva, Guatemala, Baja Verapaz, unnamed stream, 0.3 km south of La Cumbre, 1,274 m elevation, 15°00'34"N 90°13'51"W, VI-12-2001, W. D. Shepard, fluid preserved in Purdue Entomological Research Collection (PERC), West Lafayette, Indiana. Paratypes: One nearly mature larva, same data and deposition as holotype; one nearly mature larva, same data, except collected by DEB and deposited at Texas A & M University (TAMU), College Station, TX. Other material: four larvae with some parts slide-mounted, same data, at PERC; two larvae, same data, at TAMU; and two larvae at Laboratorio Entomología Sistemática, Universidad del Valle de Guatemala, Guatemala City.

*Etymology*.—The specific epithet is a noun in apposition, after the Maya Native Americans, which lived in southern Mexico and northern Central America, including the Guatemalan region.

*Discussion*.—*Lugoiops maya* was collected from a torrential mountain rivulet of

only a few centimeters in width and depth that was coursing down a deep and narrow-sided crevice at about a 30° grade. Larvae were clinging to rocky substrate. Other mayfly species collected at this site were also members of the *Baetodes* complex, including *B. noventus* Cohen and Allen, *B. deludens* Lugo-Ortiz and McCafferty, and *Mayobaetis ellenae* (Mayo). The former two were also found clinging in the rapid current, but *M. ellenae* was taken in the splash zone along the side of the stream. Lugo-Ortiz and McCafferty (1996) indicated that the more plesiotypic members of the *Baetodes* complex were often found in moderate current and splash zone environments in the Neotropics. Observations of splash-zone habitation had been made previously by WPM in Costa Rica for *Moriobaetis maculipennis* (Flowers). Lugo-Ortiz and McCafferty (1996) also noted that *Baetodes* and *Prebaetodes* were, however, known as clingers in current. To this latter adaptive grouping, can now be added *Lugoiops*. Lugo-Ortiz and McCafferty (1996) showed correlation between habitat and morphological transitions within the *Baetodes* complex. Based on this, the new data we present for *Lugoiops* would have been to a large extent predictable.

#### ACKNOWLEDGMENTS

We thank Arwin Provonsha (West Lafayette, IN) for the illustrations used herein, Pat Randolph and Lu Sun (West Lafayette, IN) for technical assistance, and Bill Shepard (Sacramento, CA) for contributing specimens. Mike Meyer and Pat Randolph (West Lafayette, IN) commented on early drafts of the manuscript. Jack Schuster and Enio Caño (Guatemala City, Guatemala) helped with collecting permits.

#### LITERATURE CITED

- Cohen, S. D. and R. K. Allen. 1978. Generic revisions of mayfly nymphs III. *Baetodes* in North and Central America (Baetidae). *Journal of the Kansas Entomological Society* 51: 253–269.
- Edmunds, G. F., Jr., S. L. Jensen, and L. Berner. 1976.

- Mayflies of North and Central America. University Minnesota Press, Minneapolis. 330 pp.
- Jacobus, L. M. and W. P. McCafferty. 2001. Contribution to the systematics of *Afrobaetodes* Demoulin (Ephemeroptera: Baetidae). *African Entomology* 9: 97–103.
- Lugo-Ortiz, C. R. and W. P. McCafferty. 1996. Phylogeny and classification of the *Baetodes* complex (Ephemeroptera: Baetidae), with description of a new genus. *Journal of the North American Benthological Society* 15: 367–380.
- . 1999. A new genus of small minnow mayflies from New Guinea and New Britain. *Annales de Limnologie* 35: 57–70.
- Lugo-Ortiz, C. R., H. M. Barber-James, W. P. McCafferty, and R. C. deMoor. 2001. A non-paraphyletic classification of the Afrotropical genus *Acanthiops* Waltz and McCafferty (Ephemeroptera: Baetidae). *African Entomology* 9: 1–15.
- McCafferty, W. P. 1998. Ephemeroptera and the great American interchange. *Journal of the North American Benthological Society* 17: 1–20.
- . 1999. Biodiversity and biogeography: examples from global studies of Ephemeroptera. *Proceedings of the Symposium on Nature Conservation and Entomology in the 21<sup>st</sup> Century*, Entomological Society of Korea, Chonan, Korea 1999: 3–22.
- McCafferty, W. P. and R. D. Waltz. 1990. Revisionary synopsis of the Baetidae (Ephemeroptera) of North and Middle America. *Transactions of the American Entomological Society* 116: 769–799.
- McCafferty, W. P., M. J. Wagle, and R. D. Waltz. 1994. Systematics and biology of *Acentrella turbida* (Ephemeroptera: Baetidae). *Pan-Pacific Entomologist* 70: 301–308.
- Waltz, R. D. and W. P. McCafferty. 1985. *Moribaetis*: a new genus of Neotropical Baetidae (Ephemeroptera). *Proceedings of the Entomological Society of Washington* 87: 239–251.